

HV VCV Lines for the Production of High and Extra High Voltage Cables

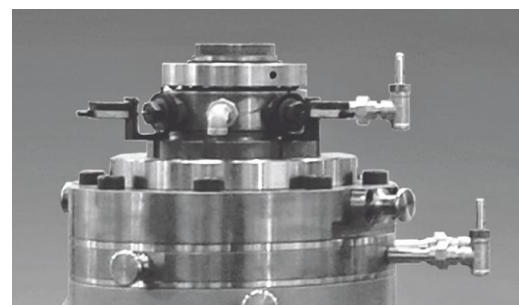
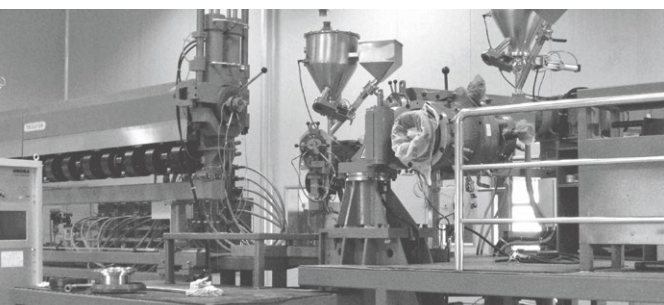
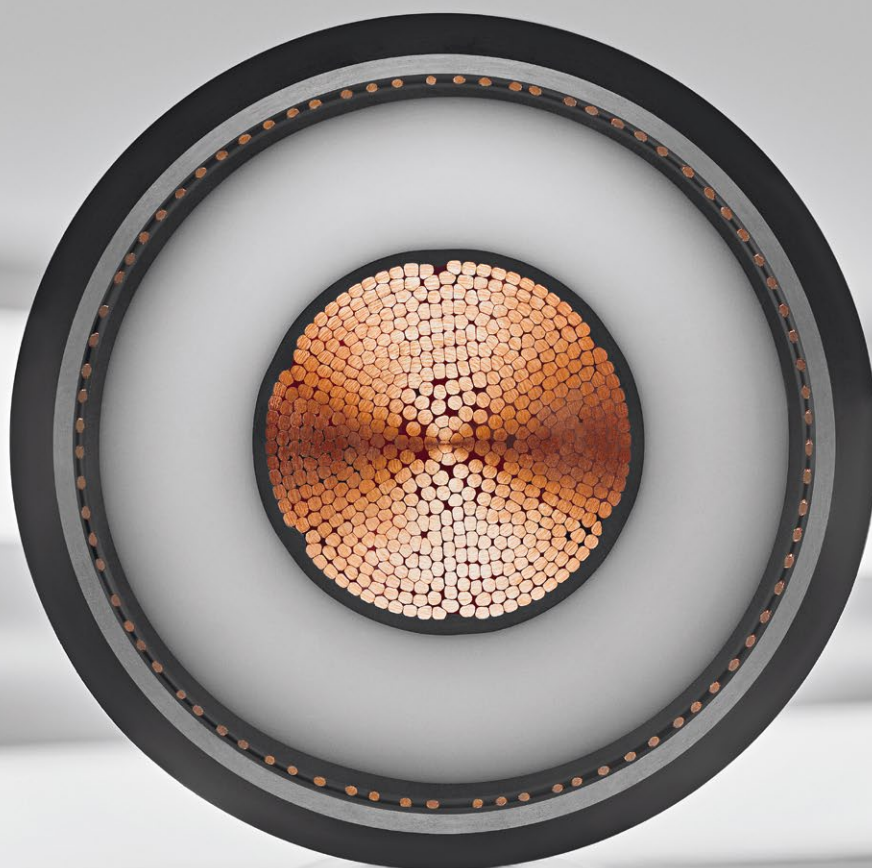

TROESTER

EXCELLENCE IN EXTRUSION.

HV VCV Lines for the Production of High and Extra High Voltage Cables



TROESTER VCV Line

The TROESTER HV VCV Line has many outstanding features tailored to the highly efficient production of cables, cores and insulated wires in the HV and EHV range.

With latest extrusion technology like triple cross heads with conical material distributors and precise temperature control of six independent heating zones the TROESTER VCV line guarantees the production of cable cores with excellent tolerances of all three layers. The crosslinking of the cables is done through a heating concept using induction preheating, postheating and tube heating by energy efficient resistance heaters. With its individual adjustment it guarantees high production speeds at optimized curing conditions.

A TROESTER-developed line control system which is optimally matched to the vertical line ensures safe and easy handling and operation of this cable line.

For the insulation of cores, TROESTER supplies CCV Lines as well as VCV Lines (vertical lines). All TROESTER machines and lines for the production of power cables stand out for their excellent manufacturing quality. This is proved in daily production by high efficiency and profitability. The TROESTER technology, combined with continuous work on innovations and further technical development, is always a guarantee for our customers to receive a complete product range from one company, based on state-of-the-art technology.

The worldwide customer satisfaction with TROESTER can also be attributed to further reasons: superior process technology resulting from the development of efficiently operating machines and lines with long operating lives; perfected technology for machine and line control systems; qualified service support which is efficiently managed to ensure that our customers are able to produce high-quality cores, insulated wires and cables.

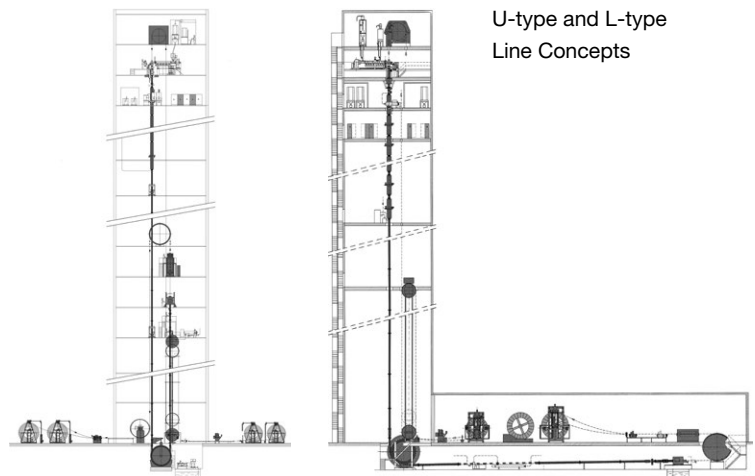

U-type and L-type Line Concepts

Main Advantages of TROESTER HV VCV Lines

- > Excellent core tolerances for HV/EHV cables
- > Material saving production
- > Superior process technology
- > Super clean process conditions
- > Preheating, postheating, tube heating
- > Long and stable production runs
- > Innovative line concepts: L-type, U-type, V-type
- > Customized lines to suit individual requirements

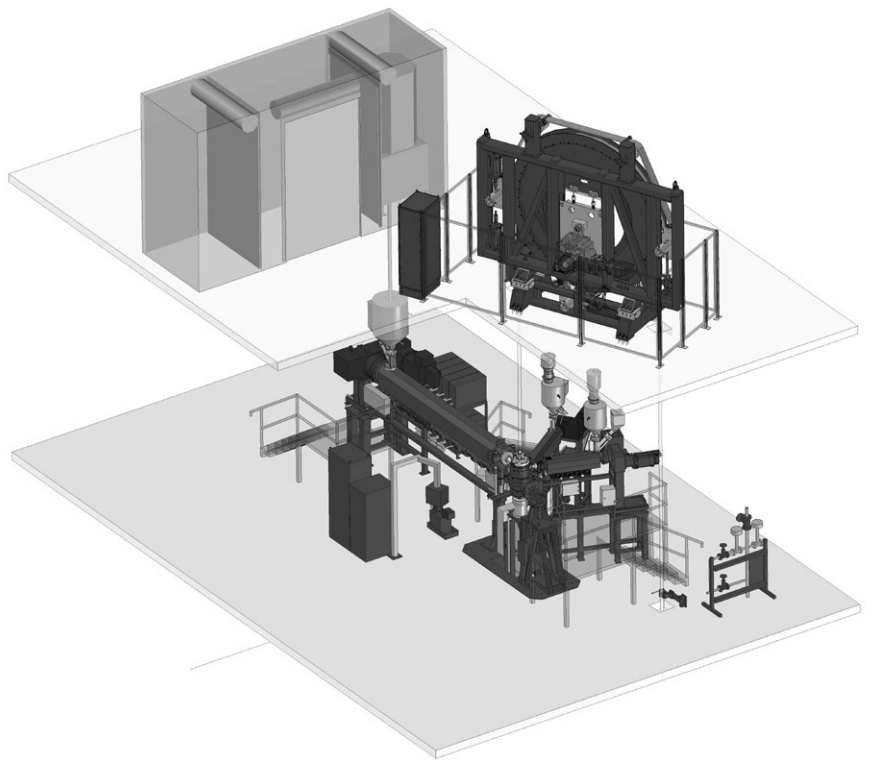
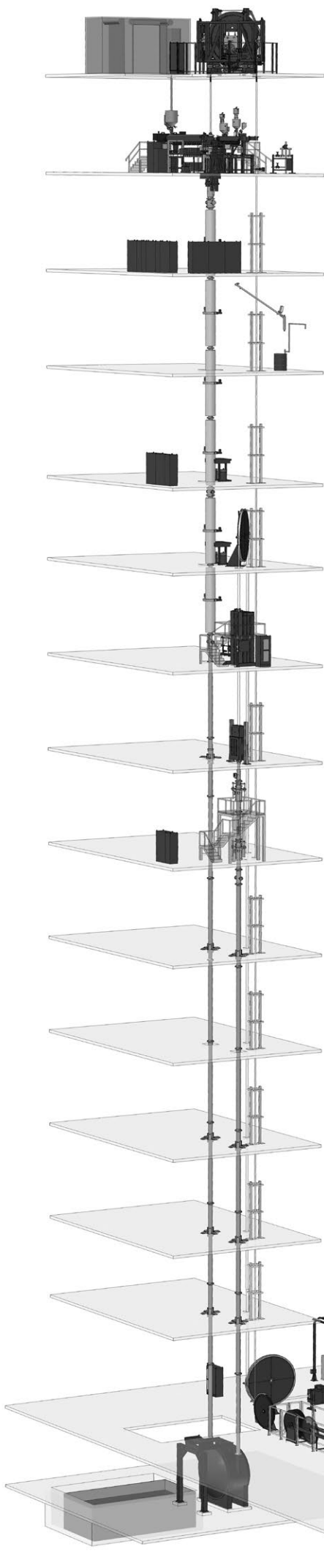

Capstan, Material Handling (INSUL) and Extruder Group



Turn Around
Pressure Vessel



Vertical Head



Extruder Group

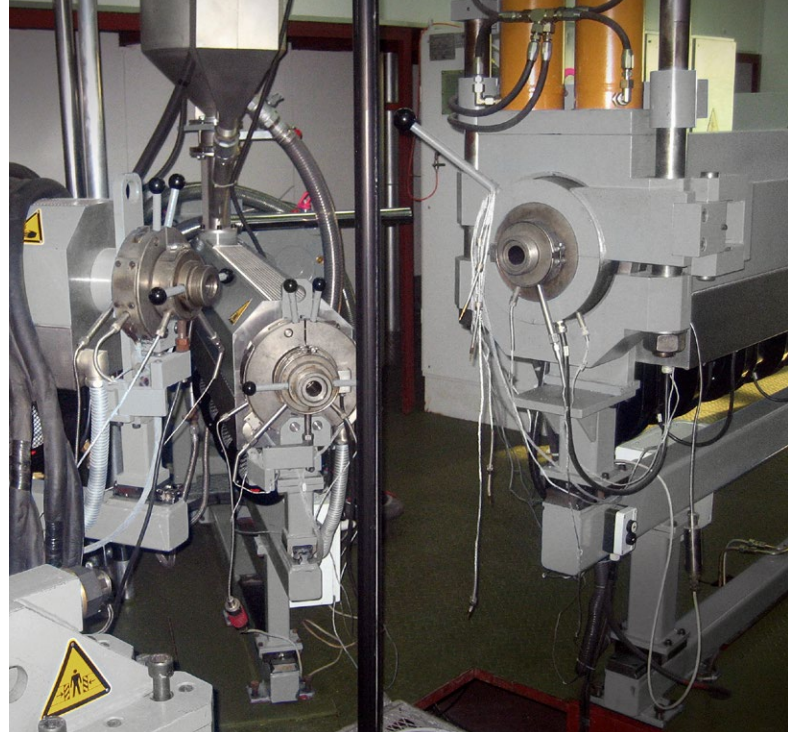

Extruder Group

Line Characteristic (Example)

Voltage class	kV	110 - 1.000
Conductor cross section	mm ²	240 - 3500
Wall thickness		
Inner semi-conductor	mm	1,2 - 3,0
Insulation	mm	16,5 - 45,0
Outer semi-conductor	mm	1,2 - 3,0
Cable diameter max.	mm	170
Cable weight max.	kg/m	50
Length of the line (Heating section / Tube length)	m	40 / 144 + 50
Line speed max.	m/min	15
Extruder group		
Extruder		PXA 75 / 200 / 90
Triple cross head		TQu 100 X



Triple Cross Head
in a VCV Line



EXCELLENCE IN EXTRUSION.

TROESTER GmbH & Co. KG
Am Brabrinke 1-4
30519 Hannover, GERMANY
Phone +49-511-87040
Fax +49-511-864028
E-mail innovations@troester.de
www.troester.de

TROESTER
North & Central America
Cable and Compounding Machinery
875 Elm Street, Apt 215
Manchester, NH 03101, USA
Phone +1-603-218-3084
Cell +1-603-867-3105
E-mail eugenio.urbina@troester-group.com

TROESTER Machinery
(Shanghai) Co., Ltd.
Workshop No. 1, Area C
No. 6999 Chuan'sha Road, Pudong
Shanghai 201202, PR CHINA
Phone +86-21-58598308
Fax +86-21-58598310
E-mail info@troester.cn
www.troester.cn

X-Compound GmbH
Hardmatt 932
CH -5082 Kaisten, Switzerland
Phone +41-62-869 10 30
Fax +41-62-874 32 08
E-mail info@x-compound.com
www.x-compound.com