

MV CCV Lines for Medium Voltage Cables

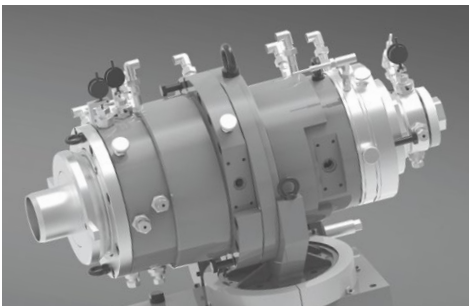
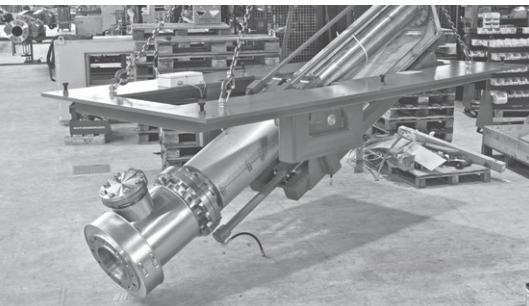

TROESTER

EXCELLENCE IN EXTRUSION.

MV CCV Lines for Medium Voltage Cables

To obtain best value when investing in MV CCV lines, TROESTER has focused on the most important characteristics to make a highly efficient product range of cables, core and insulated wires possible.

High production speeds

For TROESTER's High-Output Concept, two insulation extruders and two semi-conductor extruders are extruding on one Triple Cross Head. In combination with extended curing and cooling capacities top production rates can be obtained. Well optimized conductor preheaters and the TROESTER Triple Cross Head also play key roles in achieving this high level of performance.

nitrogen environment under pressure and temperature, cooling can then be carried out using water or nitrogen as well. Consequently, cable manufacturers have maximum flexibility when producing high-quality cables.

The substantial level of in-house manufacturing at TROESTER guarantees direct control of quality, costs and delivery time of the CV lines. Highly-skilled engineers incorporate innovative developments and experience directly in the machine components like extruders, extruder heads, CV tubes, cable machinery and line controls. The result is constant improvement of all machines and line components.

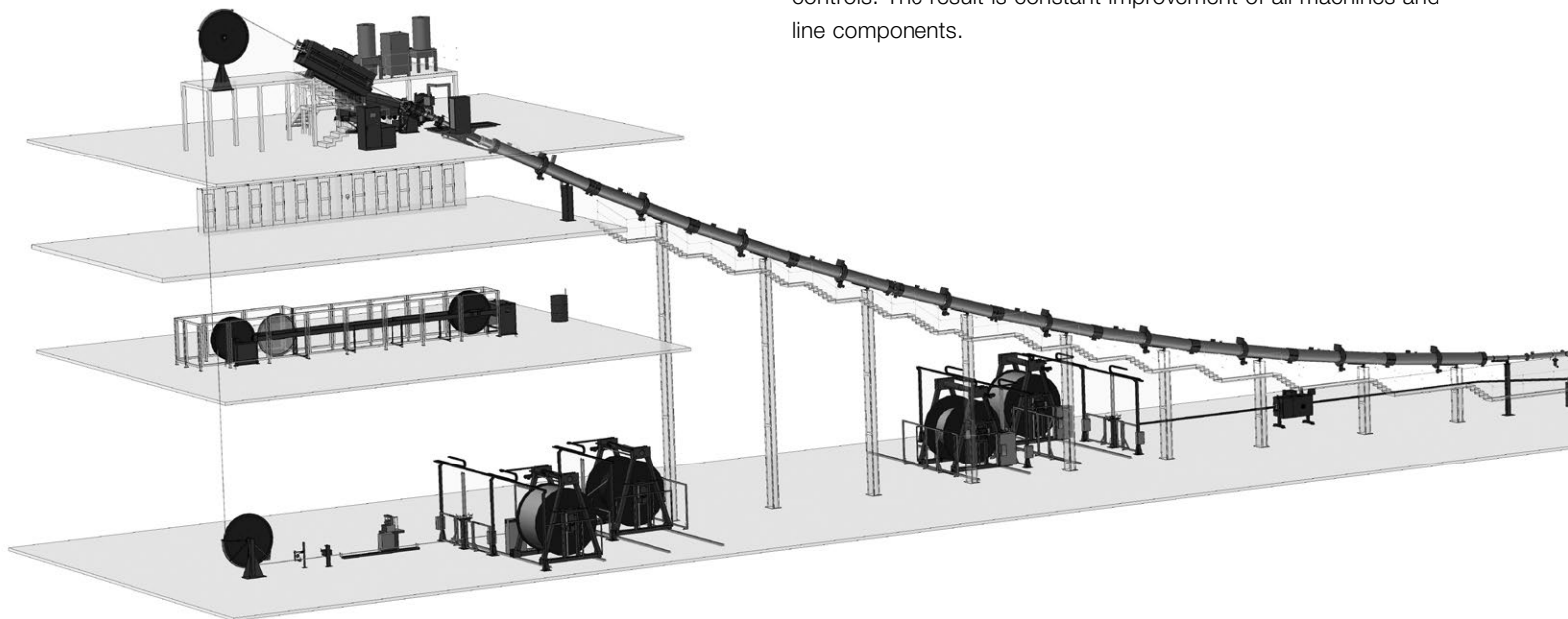

Fast product changes

Products are often made to order to ensure manufacturers can keep their stock as low as possible. To guarantee a CV line is operating at full capacity, several product changes frequently have to be made. TROESTER CCV lines comply with these demands thanks to short tool-change times, as well as the variable endseal TRENDSEAL. The tool changes take only 15 minutes. During this time the insulation materials can remain in the extruders thanks to an advanced barrel and screw temperature control systems. The variable endseal TRENDSEAL automatically adjusts to the new cable diameter.

Processing of XLPE and EPR

Depending on the cable characteristics, in their tenders utilities specify XLPE- or EPR-insulated medium-voltage cables. In order to respond flexibly to the specifications concerned, TROESTER extruders and extrusion heads can be designed for multi-purpose use. As a result, both materials can be processed on the same machinery. TROESTER MV-CCV lines are cross-linking the cable in

Main Advantages of the MV CCV Lines from TROESTER

- > Excellent value due to significant level of in-house manufacturing
- > Fast product changes by:
 - Online centering on the triple cross head
 - Tool change in 15 minutes thanks to special tools
 - Variable Endseal TRENDSEAL
- > Scrap length is minimized by temperature guided starting-stopping process
- > High production speeds due to high-output concept and optimized conductor preheating
- > Environmental friendly components that allow both ecological and economical production, such as gas filtering system, by-product discharge and energy-savings due to CV-tube resistance heating.
- > Customized machinery concepts to suit on-site conditions

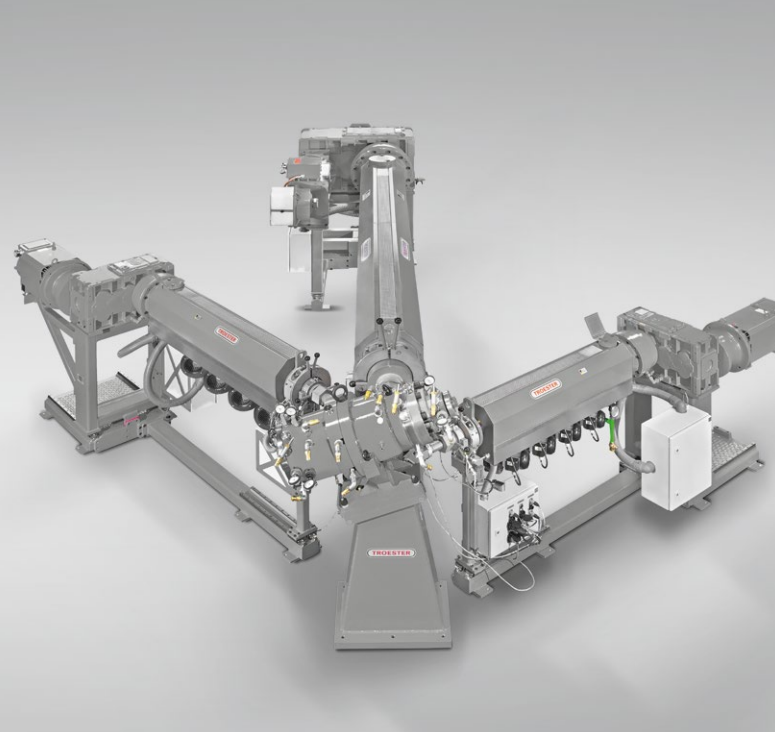

Extrusion Group

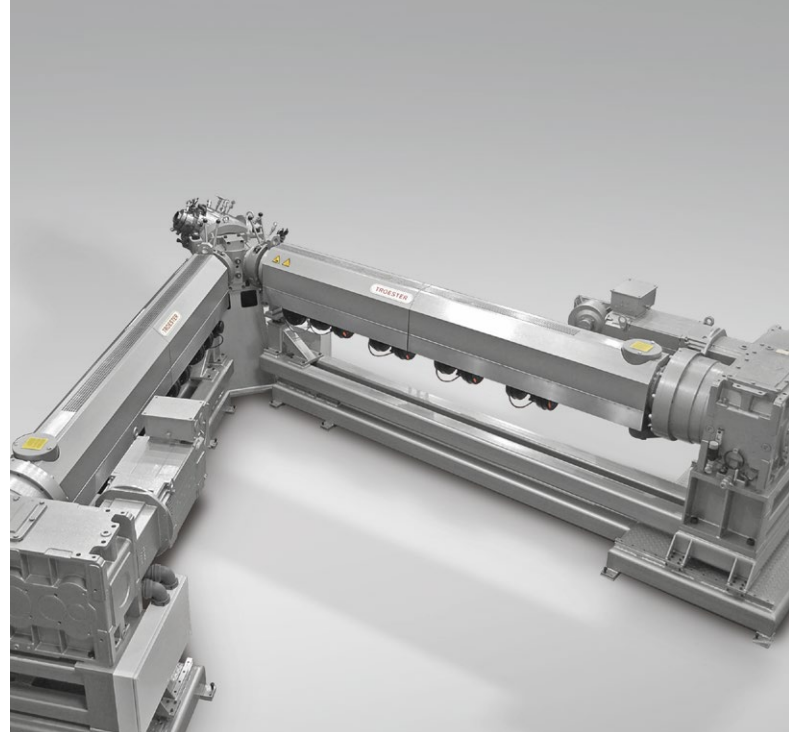

Insulation Extruders for High-Output Concept

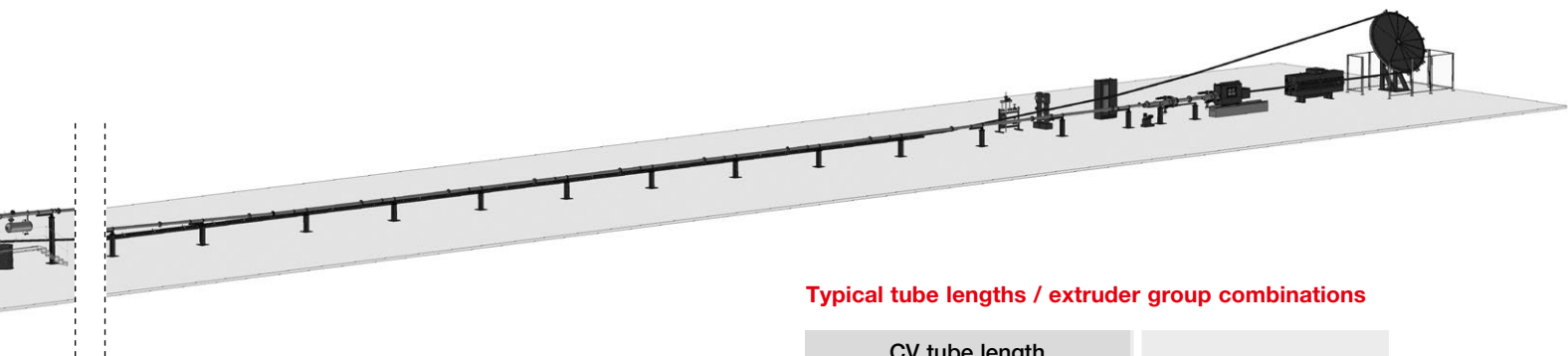

Typical tube lengths / extruder group combinations

CV tube length (Heating length / total length)	Extruder group
55 / 150 m	PXA 60 / 150 / 75
66 / 180 m	PXA 75 / 175 / 90
71 / 220 m	PXA 90 / 200 / 90
97 / 275 m	PXA 90 / 2x150 / 90



Variable Endseal TRENDEAL

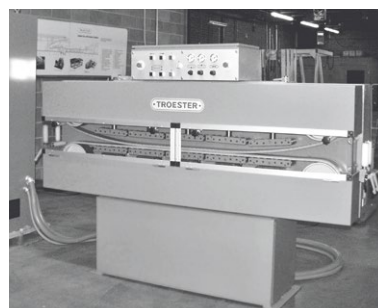

Belt-type Caterpillar AGP



Triple Cross Head TQU



Horizontal Motorized Accumulator HMS



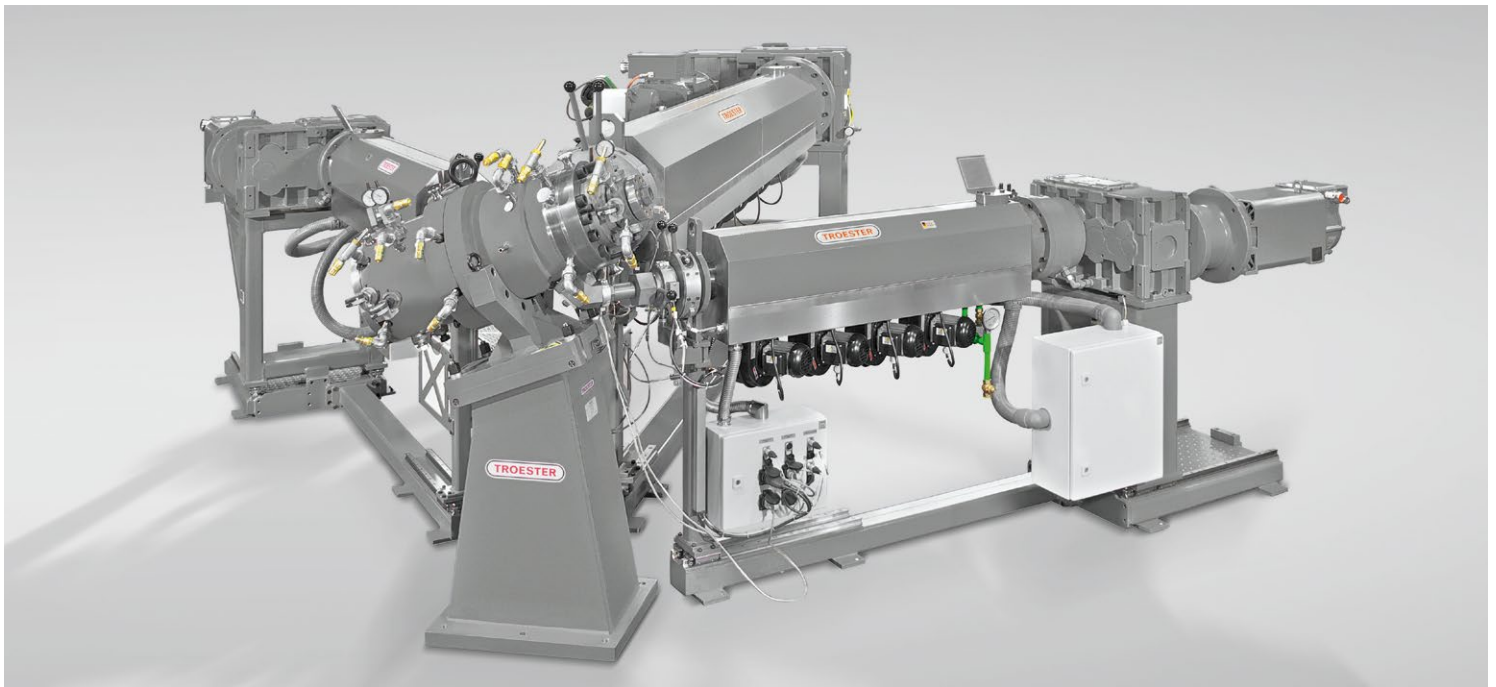

Extrusion Group

Line Characteristic (Example)

Voltage class	kV	6 – 70
Conductor cross section	mm ²	25 – 800
Wall thickness		
Inner semi-conductor	mm	0,4 – 1,5
Insulation	mm	2,3 – 13,5
Outer semi-conductor	mm	0,4 – 2,0
Cable diameter max.	mm	70
Cable weight max.	kg/m	9,5
Length of the line (Heating section / Tube length)	m	66 / 180
Line speed max.	m/min	45
Extruder group		
Extruder		PXA 75 / 175 / 90
Triple cross head		TQu 50 X



Triple Cross Head
TQu



EXCELLENCE IN EXTRUSION.

TROESTER GmbH & Co. KG
Am Brabrinke 1-4
30519 Hannover, GERMANY
Phone +49-511-87040
Fax +49-511-864028
E-mail innovations@troester.de
www.troester.de

TROESTER
North & Central America
Cable and Compounding Machinery
875 Elm Street, Apt 215
Manchester, NH 03101, USA
Phone +1-603-218-3084
Cell +1-603-867-3105
E-mail eugenio.urbina@troester-group.com
troester-group.com

TROESTER Machinery
(Shanghai) Co., Ltd.
Workshop No. 1, Area C
No. 6999 Chuan'sha Road, Pudong
Shanghai 201202, PR CHINA
Phone +86-21-58598308
Fax +86-21-58598310
E-mail info@troester.cn
www.troester.cn

X-Compound GmbH
Hardmatt 932
CH -5082 Kaisten, Switzerland
Phone +41-62-869 10 30
Fax +41-62-874 32 08
E-mail info@x-compound.com
www.x-compound.com